



# HERB HOLZMANN

Model 628  
Mobile crushing plant

TESAB ROTOCRUSHERS are used throughout the world for the crushing and recycling of a wide variety of materials.

The crushers produce an excellent cubic shape of stone, providing a high percentage reduction in one pass. Successful processing of granite, quartz, basalt, gravels, coal and limestone can be achieved, or used as a recycling unit for asphalt, bark, rubble and slag products.

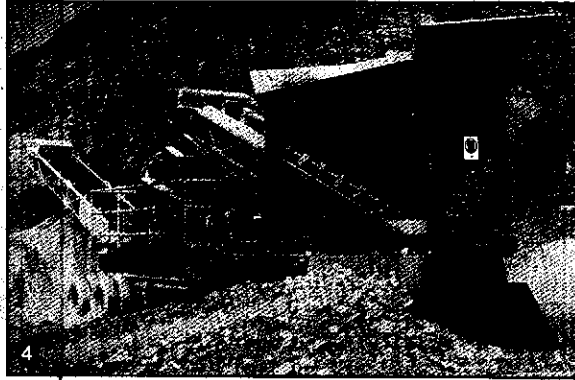
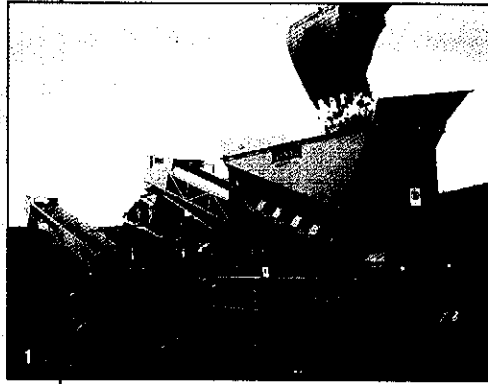

- ① TESAB Engi
- ② TESAB Sver
- ③ L'Heureux - I
- ④ Finlay Hire (I

- Feed size up to 200mm
- 100 - 150 tonnes per hour capacity
- Excellent cubic shape of product
- Environmentally friendly power unit conforms to noise and emission control levels
- Rugged chassis and conveyor construction
- Fully mobile and static crushing and screening machines
- Reversible self locking hammers and replaceable wear parts for long life and minimum maintenance.
- Used as secondary and tertiary crushers
- Ideal for recycling of reclaimed materials

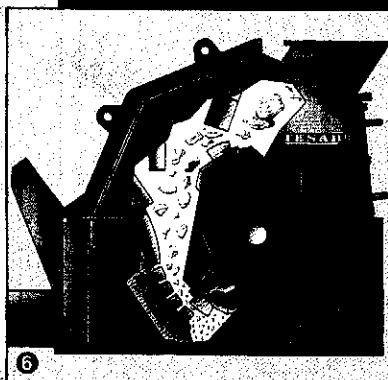
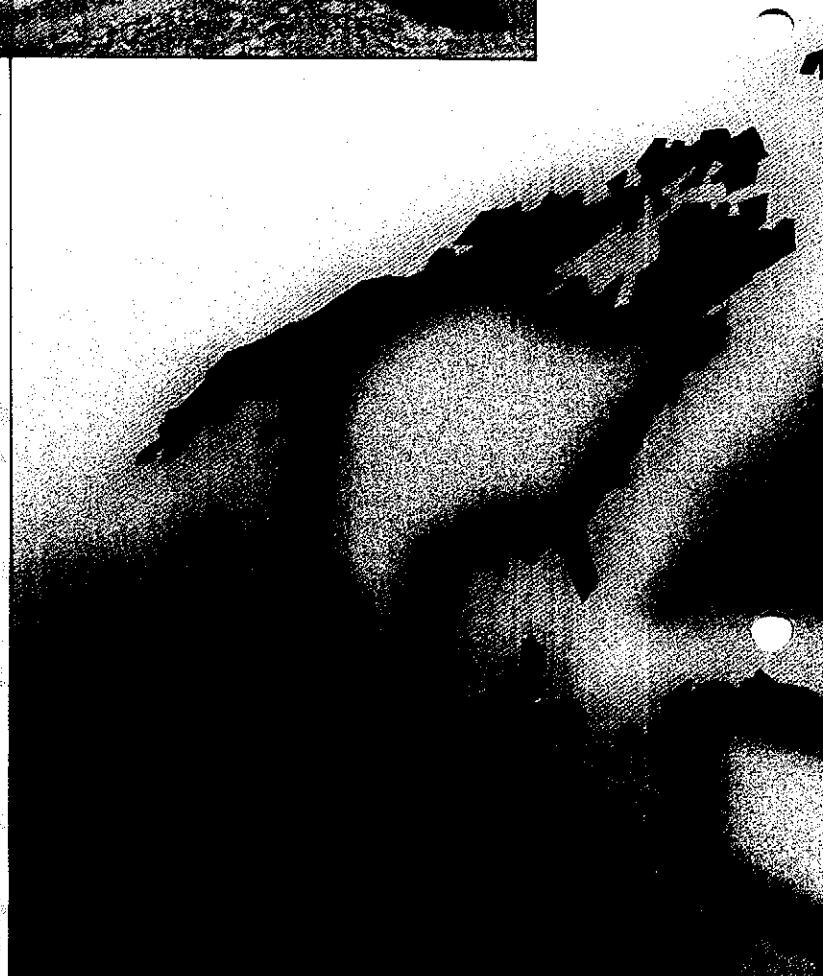

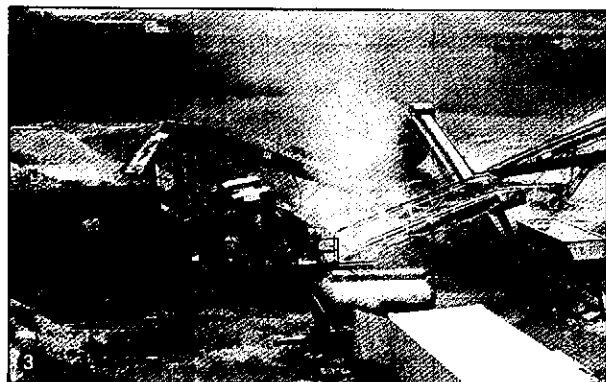

ring - Ireland  
 a - Sweden  
 ce  
 ) Quarries)

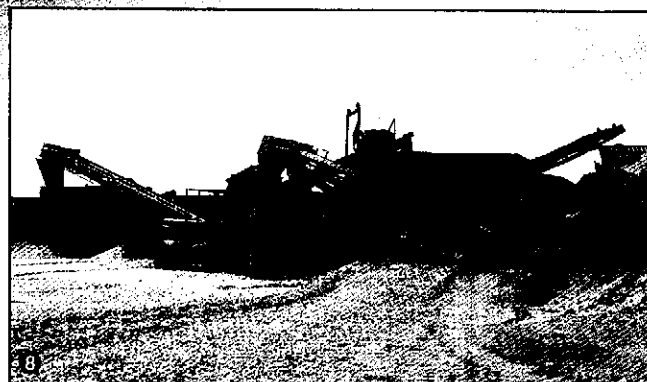
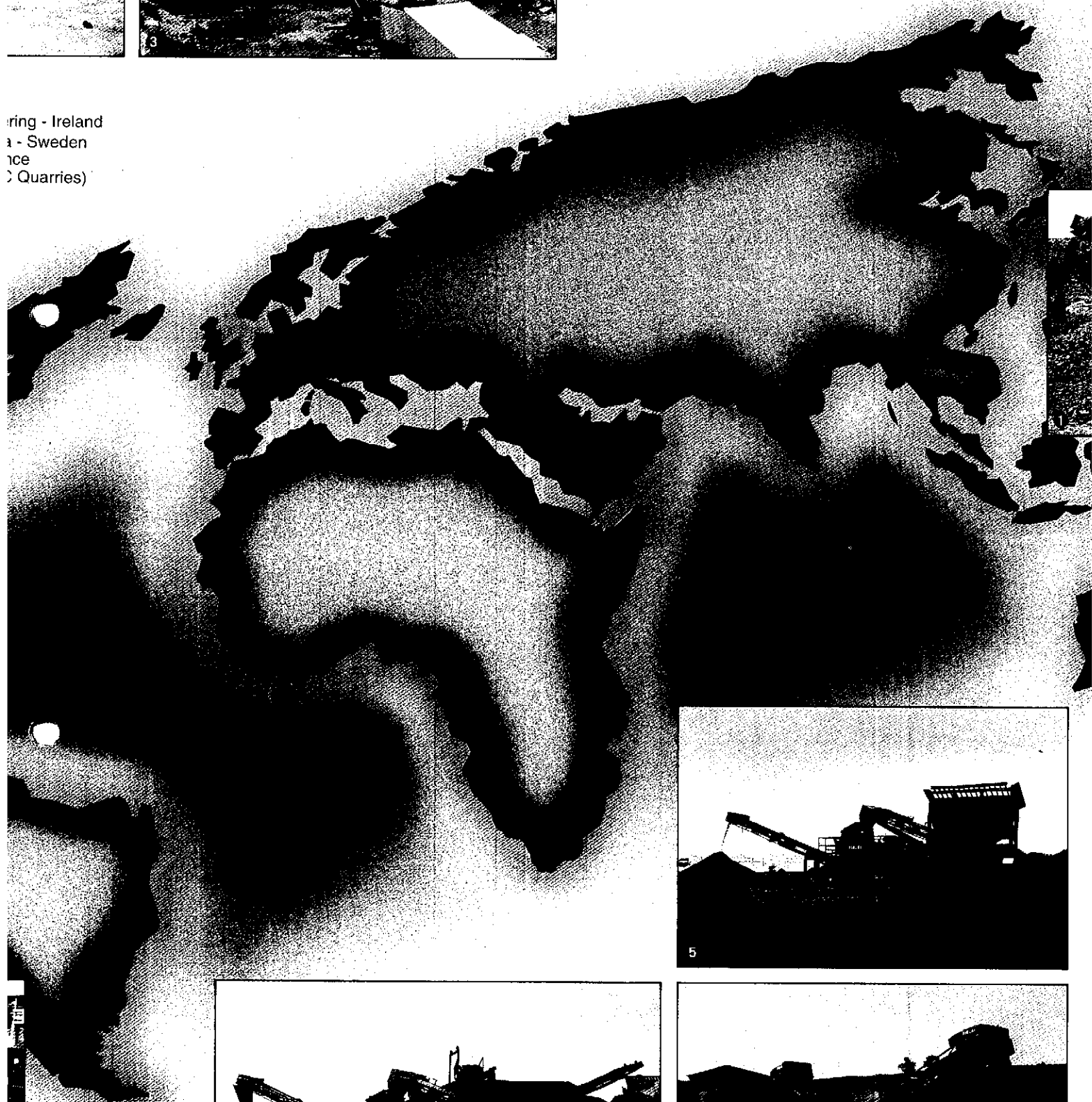

# TESAB ROTOCRUSHER

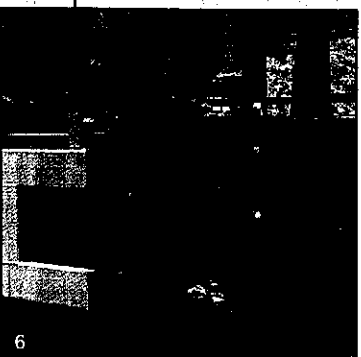
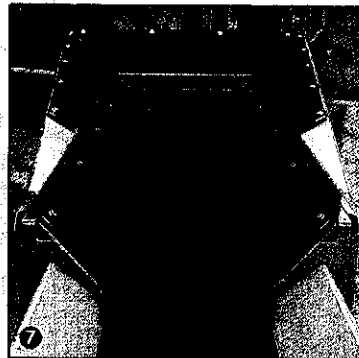
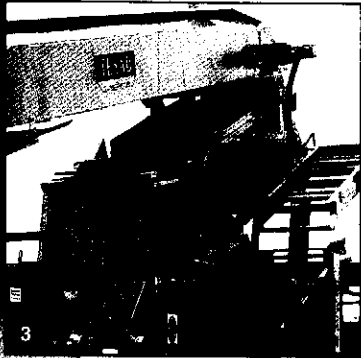
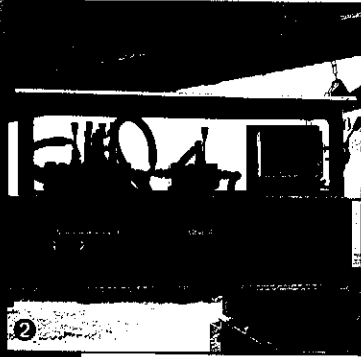

- ❶ Fines conveyor to feed another plant or simply stockpile material (643/623)
- ❷ All hydraulic set up, for fast operating position (model 643)
- ❸ Heavy duty screen box 2.0m x 0.94m (model 643)
- ❹ Safety locks on all doors to meet mine & quarry regulations (model 643)
- ❺ Safety guarding and catwalks around machine and screen box for safe operator accessibility  
Side chassis crash bars to meet all European standards (model 643)
- ❻ Road and safety regulations to European standards (model 643)
- ❼ Heavy duty rubber lined feed hopper and rubber lined skirting on feed conveyor.  
Belt widths: 650mm for feed and discharge conveyors  
Adjustable feeder belt speed with variable speed control (models 623/643)
- ❽ Twin braked and sprung axles on models 643 and 623

Finlay Hire (J Fyffe Ltd)  
TESAB Rotocrusher operation  
Manufacturing facility  
Finlay Hire (Rossington Aggregates)  
Oppermann & Fuss - Germany

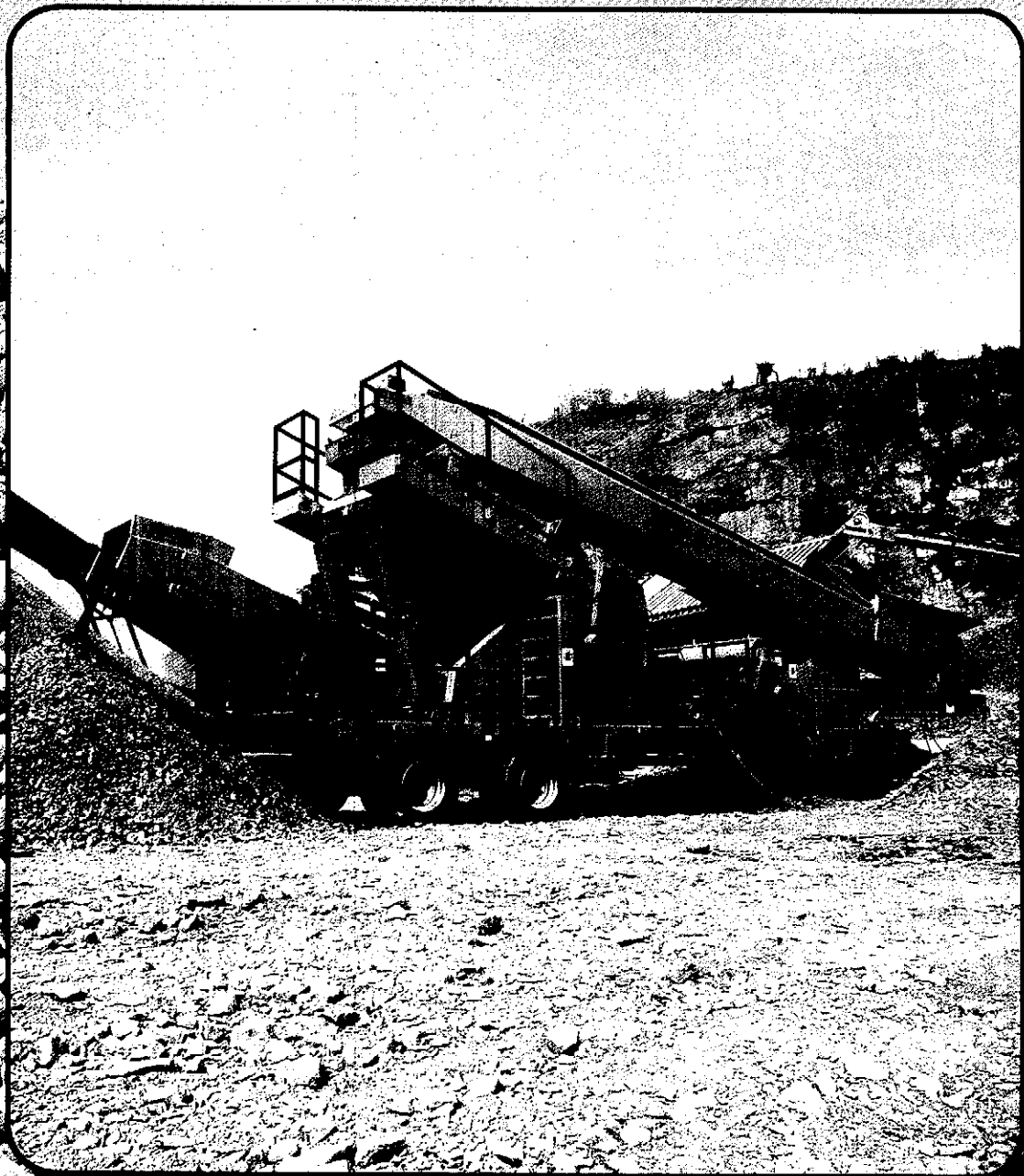

# TEREX MOBILE CRUSHER

Model 643  
mobile crushing and screening plant

### Model 623

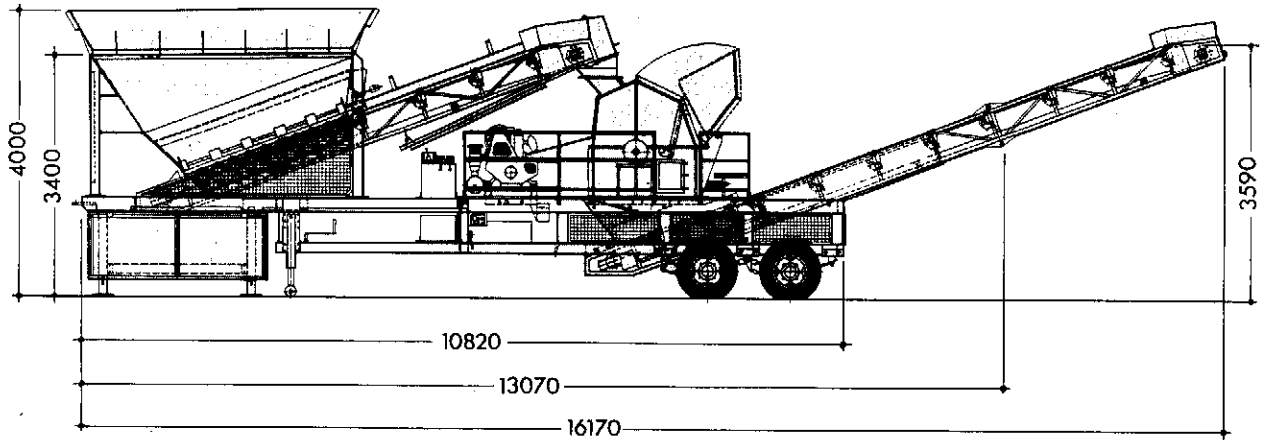

### Model 643

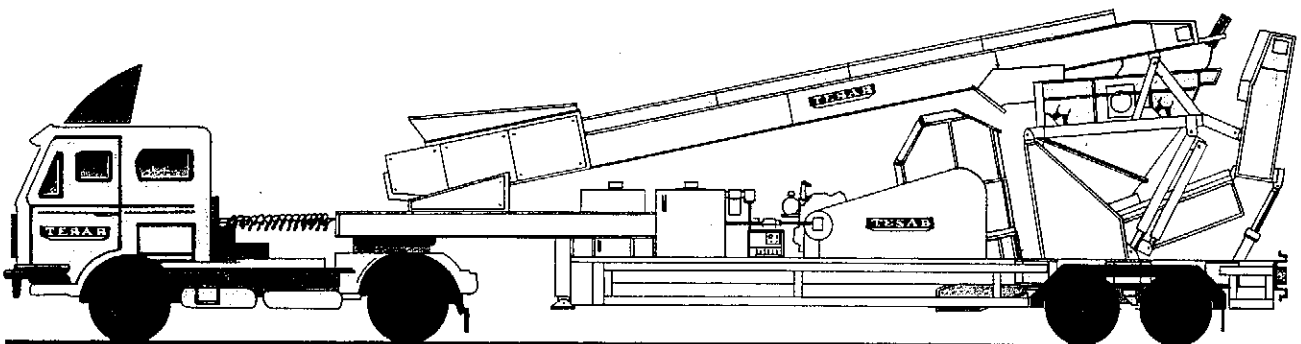
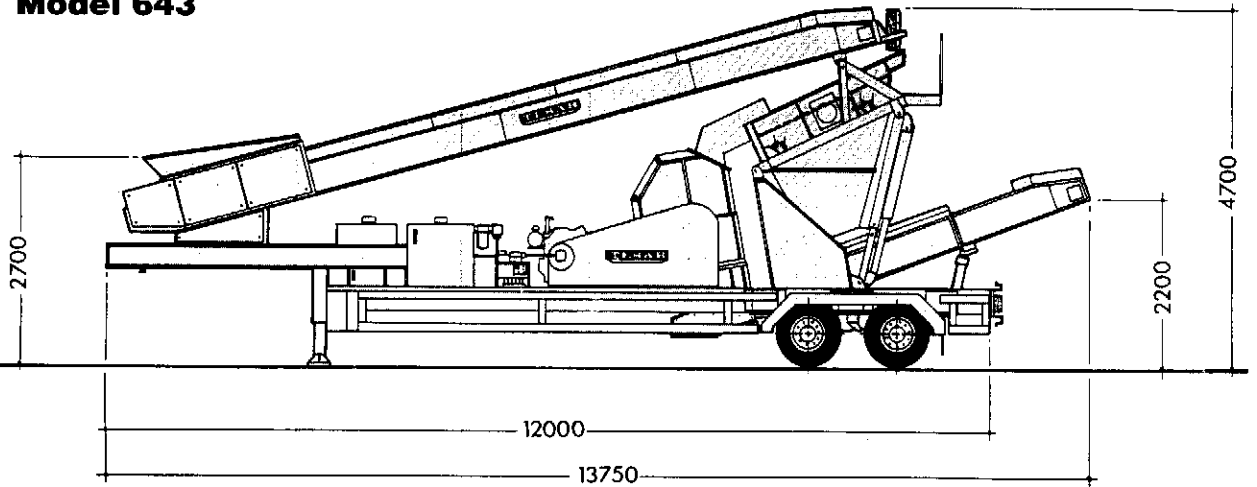

TESAB ENGINEERING have the design, technology and manufacturing facilities to produce a machine to meet specific customer requirements.



TESAB ENGINEERING LTD  
Unit 7b, Gortrush Industrial Estate,  
Omagh, Co Tyrone, N Ireland, BT78 5EJ  
Tel: 0662 252781 Fax: 0662 252801